

AXENT

SWITZERLAND

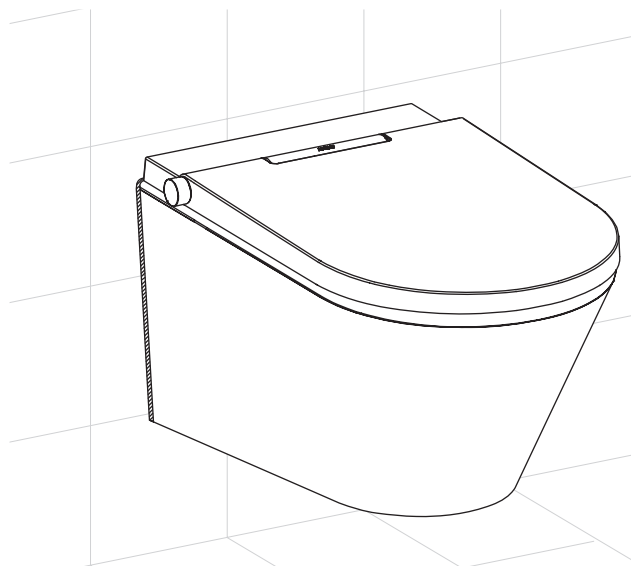

AXENT.ONE

INSTALLATION INSTRUCTION



GEFAHR

Gefahr eines elektrischen Schlags

Das Gerät darf nur an Steckdosen oder Festanschlüssen mit Schutzerdung betrieben werden.

DANGER

Electric shock hazard

The device may only be operated at power outlets or fixed connections with protective earthing.

DANGER

Risque de décharge électrique

L'appareil ne doit être raccordé qu'à des prises électriques ou des branchements fixes avec mise à la terre.

PERICOLO

Pericolo di scossa elettrica

L'apparecchio può essere utilizzato esclusivamente con prese elettriche o allacciamenti fissi provvisti di messa a terra.

GEVAAR

Gevaar van een elektrische schok

Het apparaat mag alleen aan stopcontacten of vaste aansluitingen met randaarding worden gebruikt.

PELIGRO

Peligro de descarga eléctrica

El dispositivo debe utilizarse solamente en salidas de corriente o conexiones fijas con puesta a tierra de protección.

PELIGRO

Perigo de choque eléctrico

O aparelho só pode ser utilizado em tomadas ou ligações xas com ligação à terra de protecção.

FARE

Fare for elektrisk støt

Enheden må kun anvendes på stikdåser eller fastopkoblede forbindelser med arbejdsjording.

FARE

Fare for elektrisk støt

Apparatet skal kun drives i stikkontakter eller faste tilkoblinger med jordet ledning.

VAARA

Sähköiskun vaara

Laitetta saa käyttää vain sellaisissa pistorasioissa tai kiinteissä liitännöissä, jotka on maadoitettu.



AXENT.ONE

A

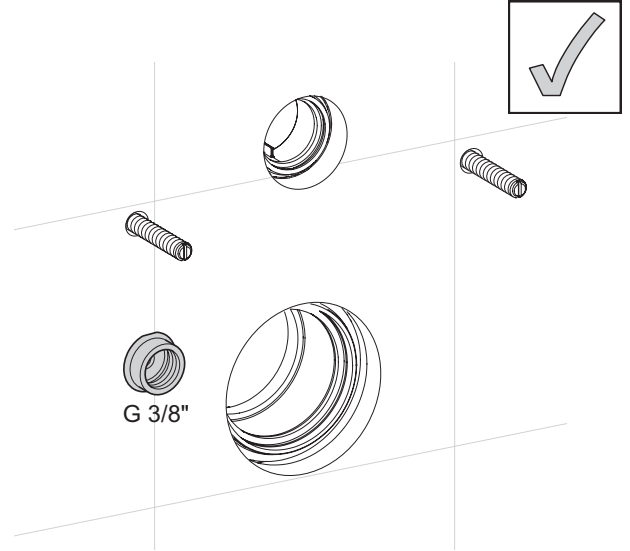
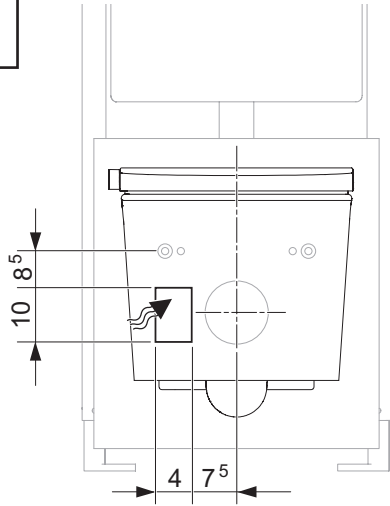

B

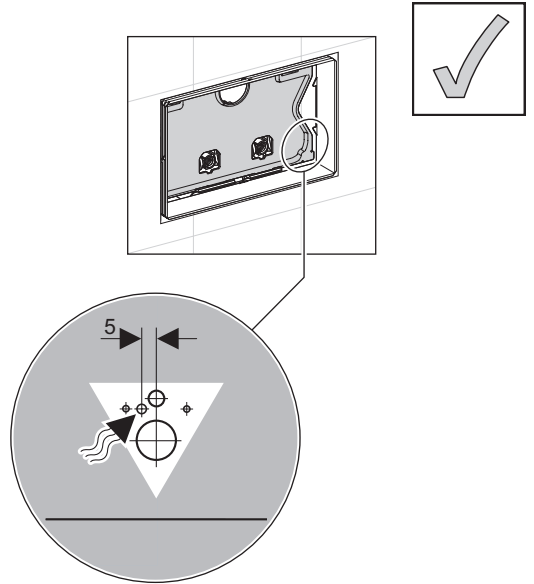
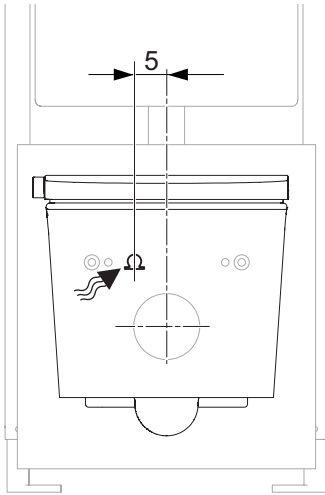

C

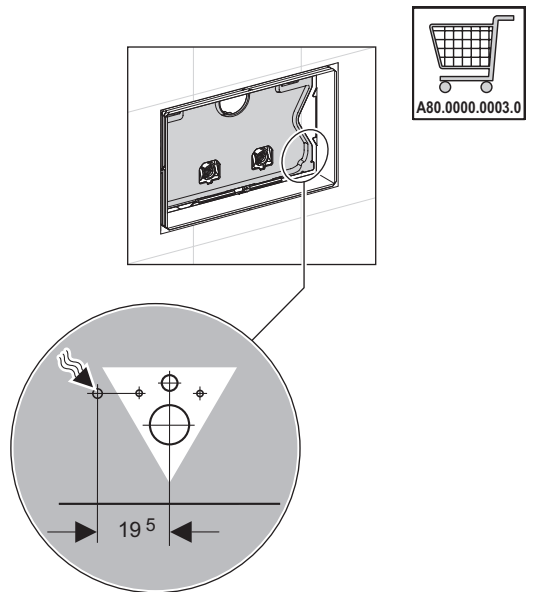
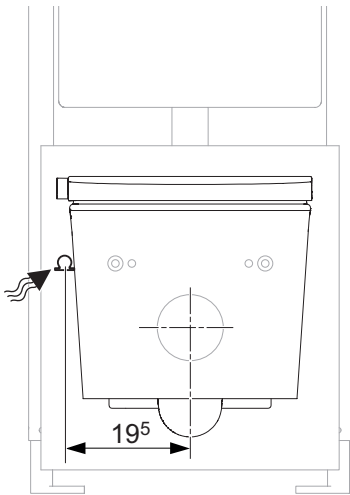



1

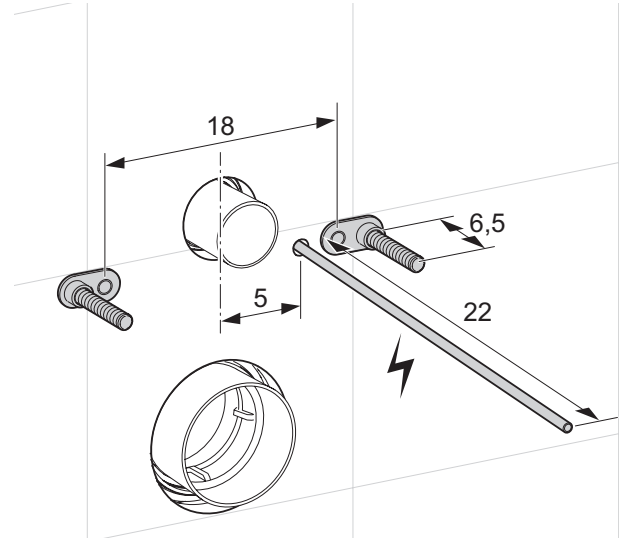
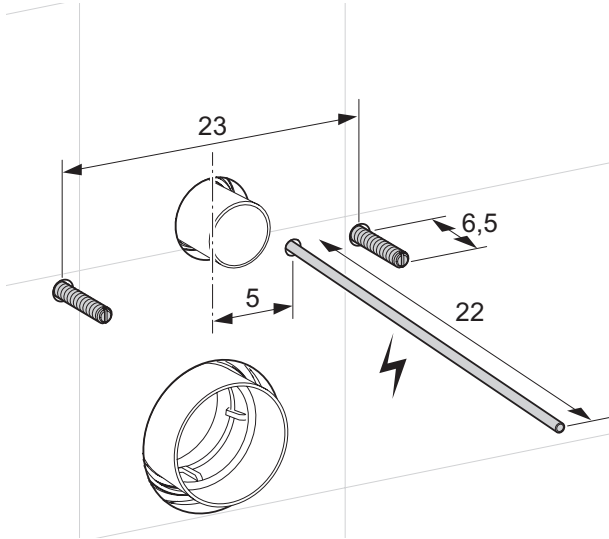

2

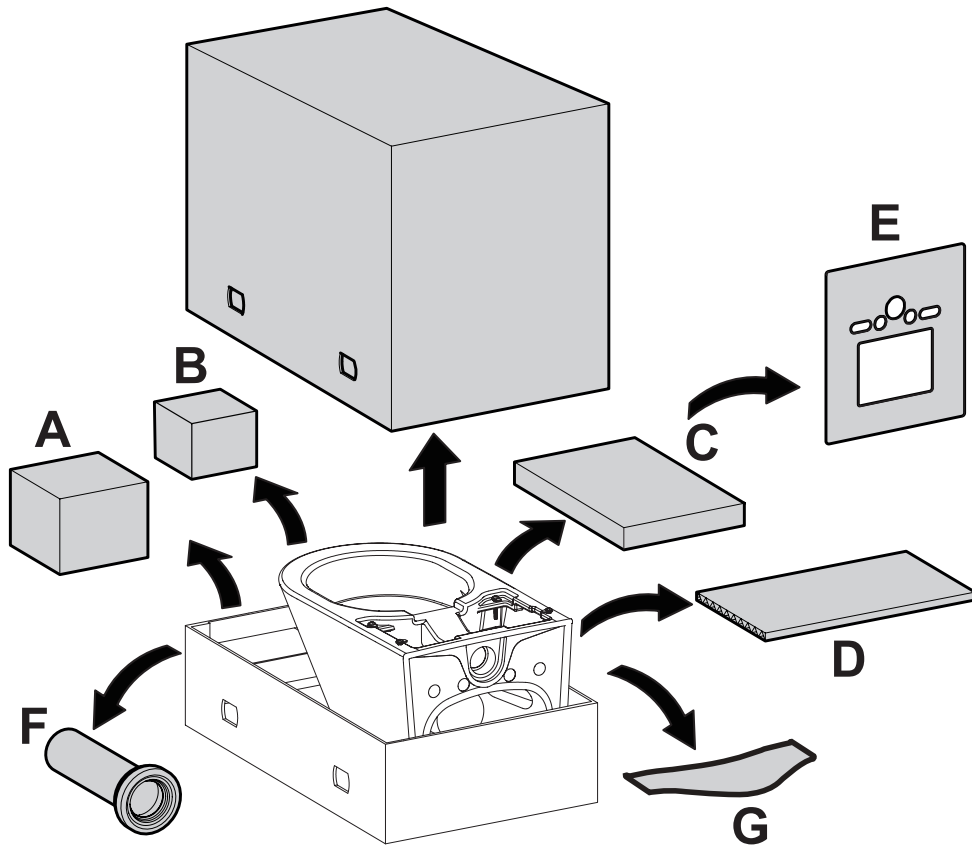



1 A

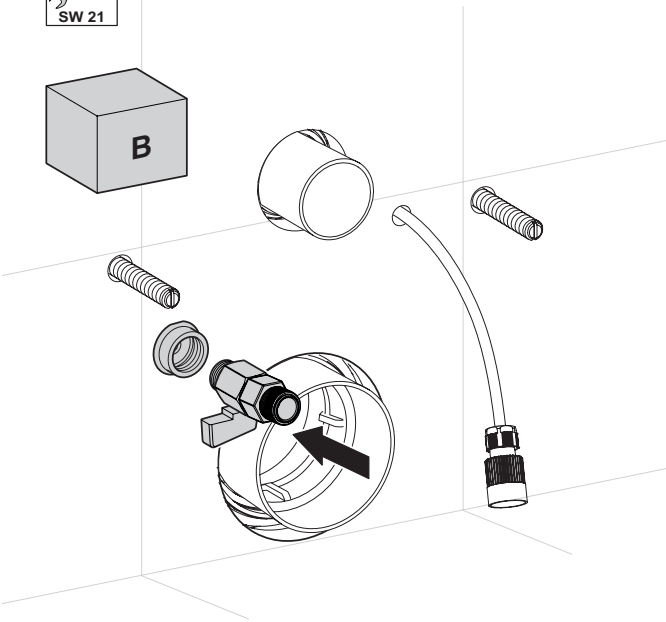
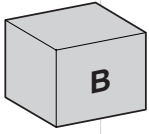

2

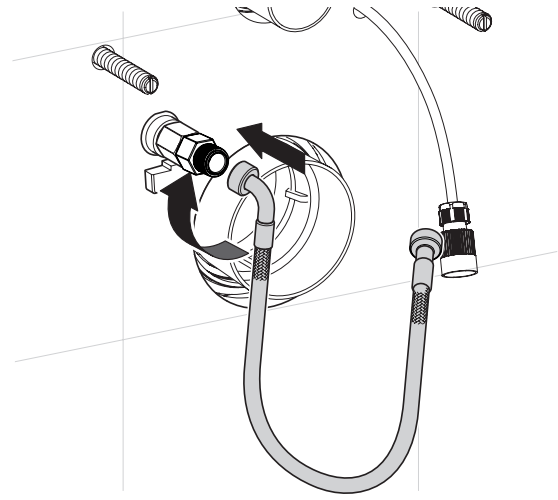

1 B

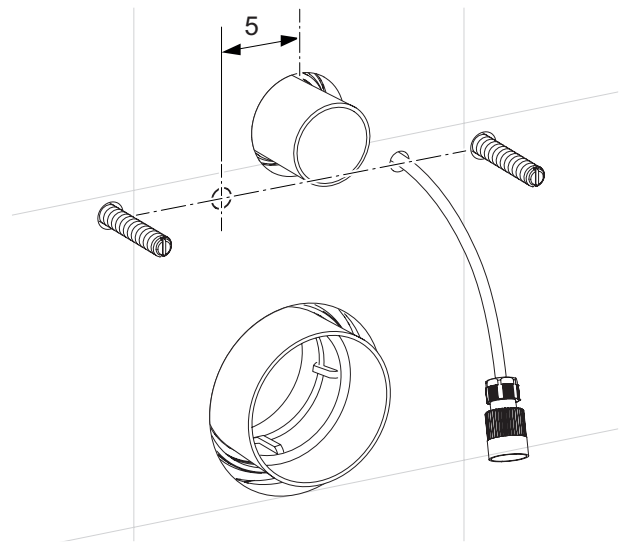
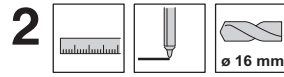
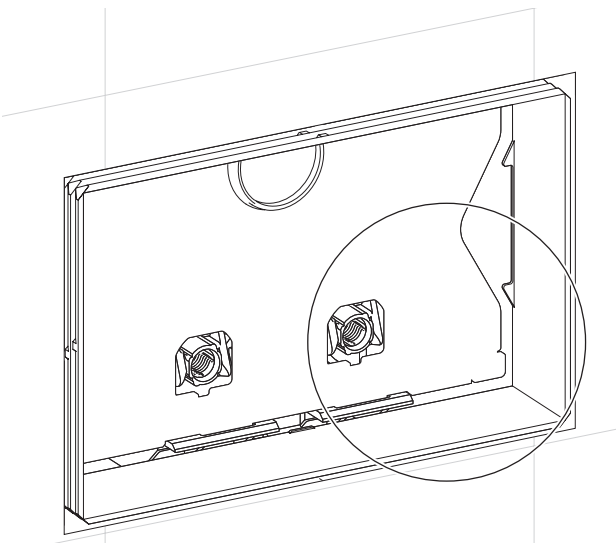
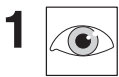

3

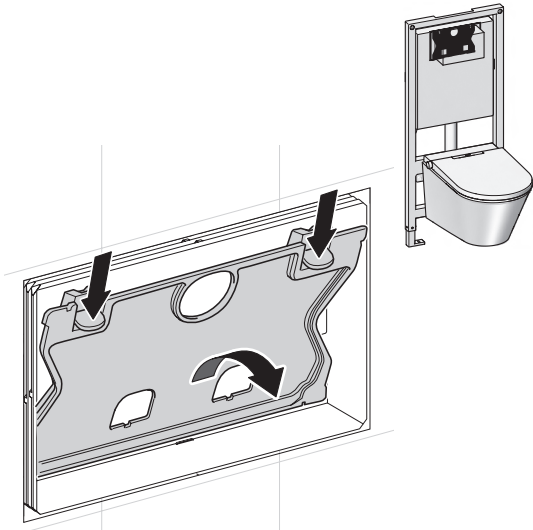

4

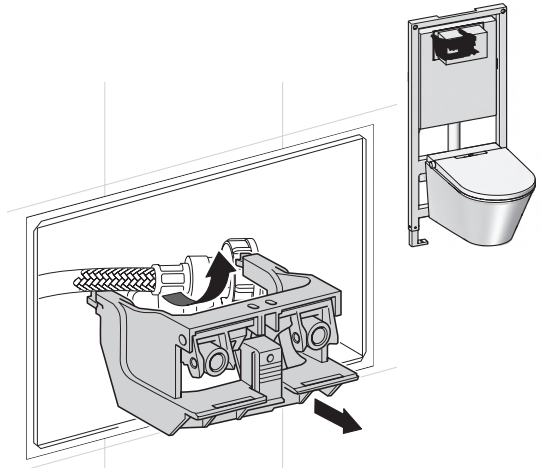

5

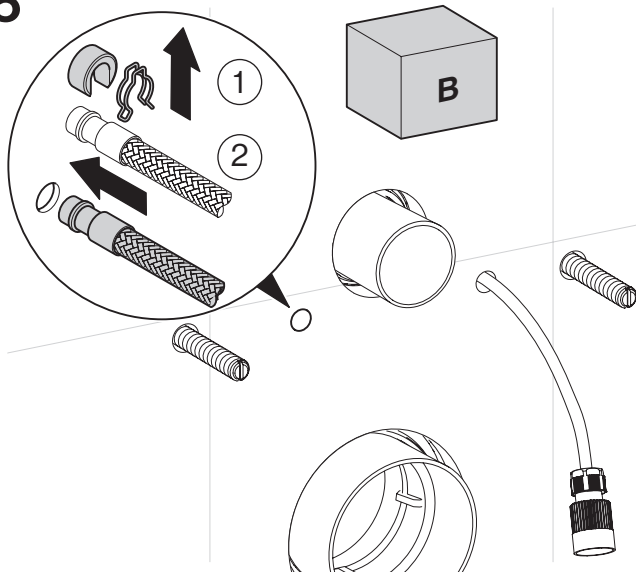

6

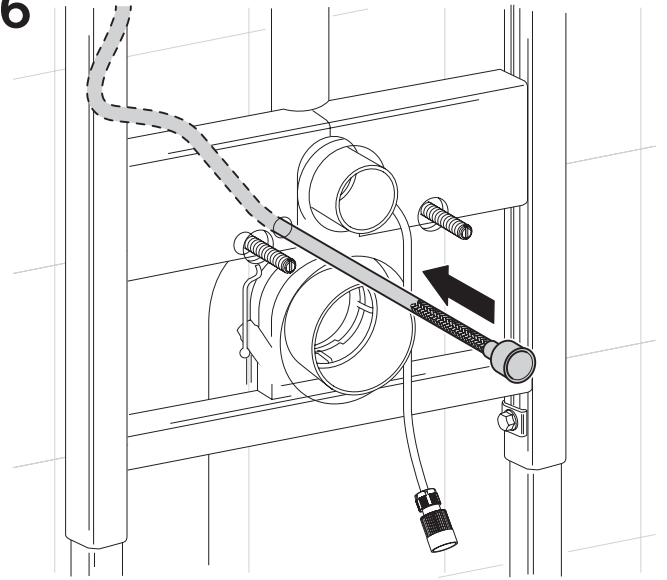

7

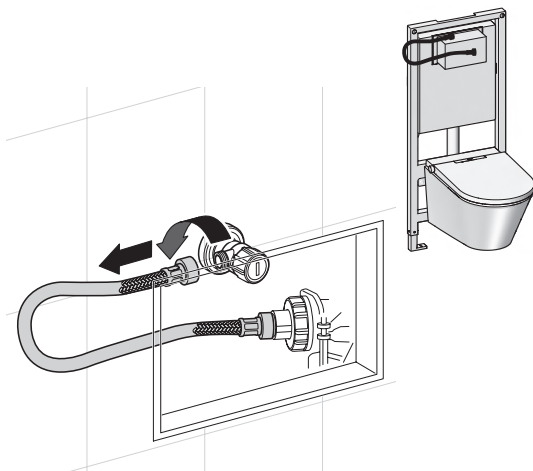

8

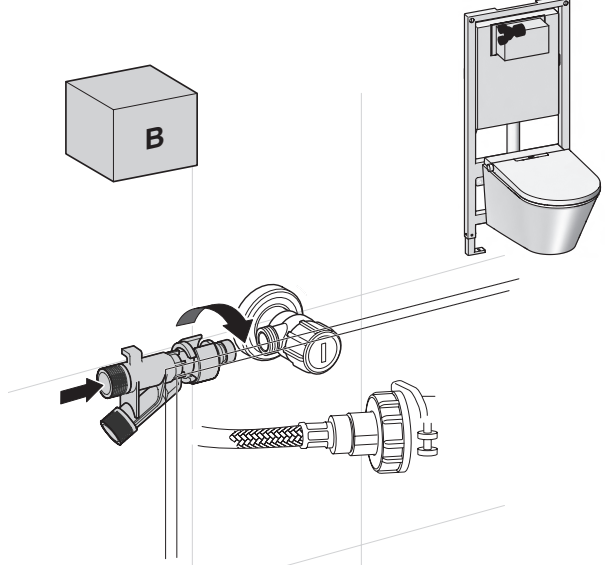

9

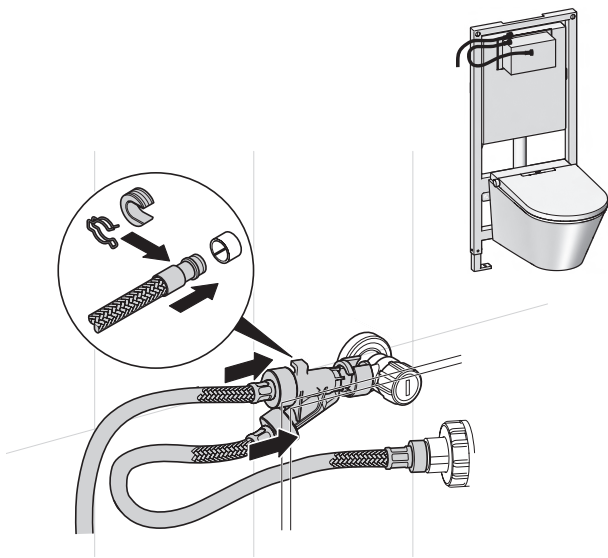

2

1

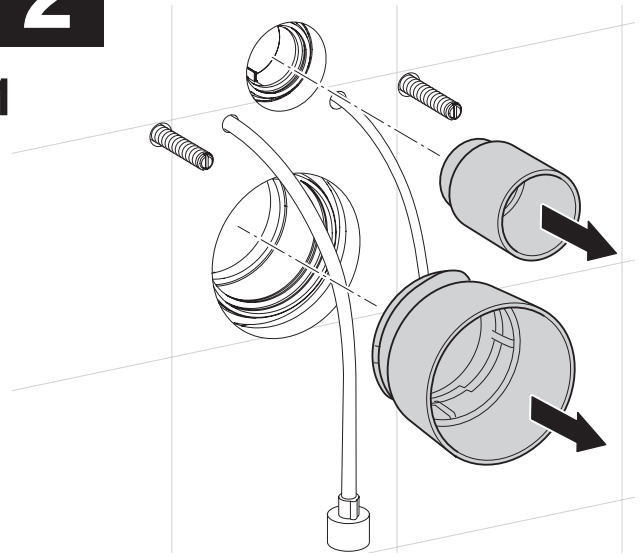

2

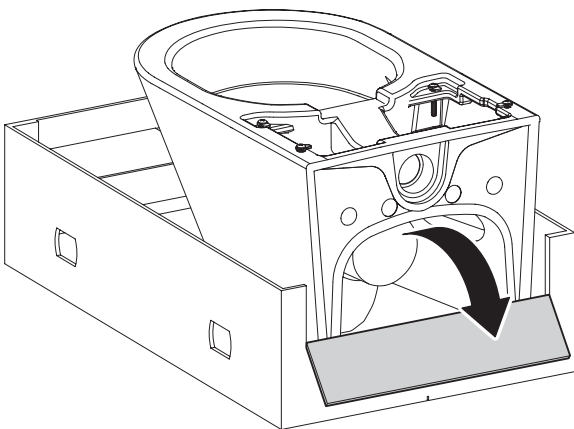

3

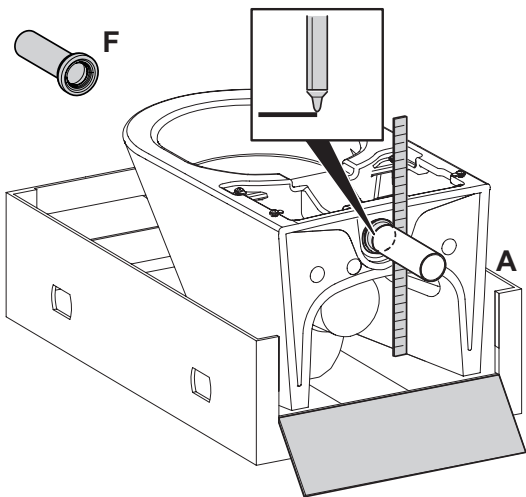
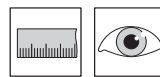

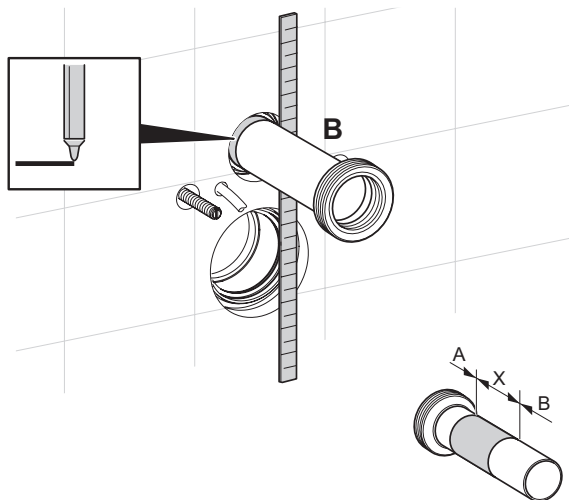
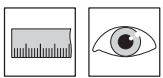

4



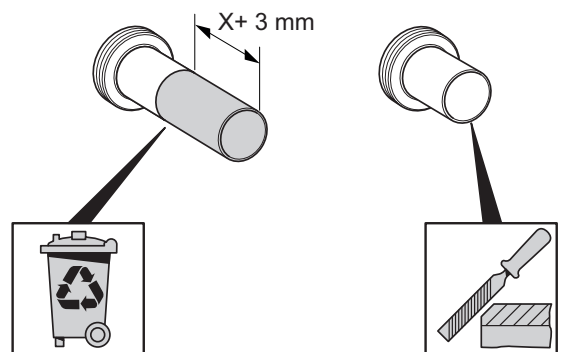

5

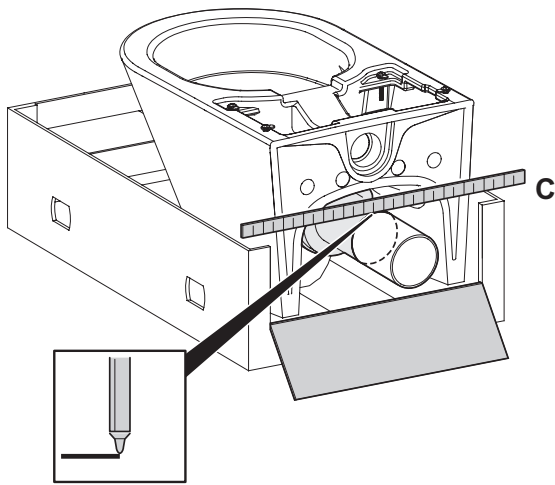

6  



7  

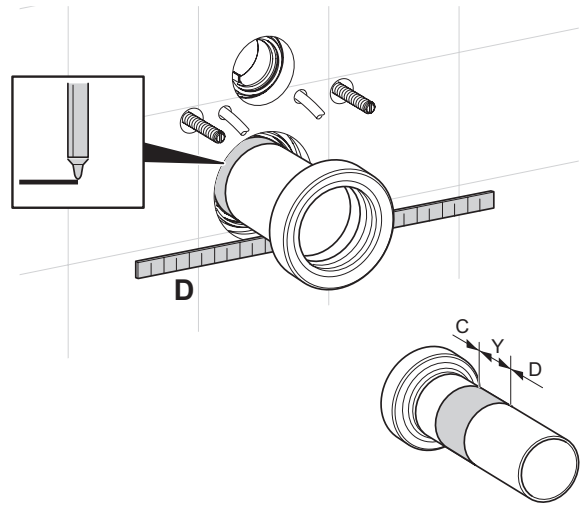

8 

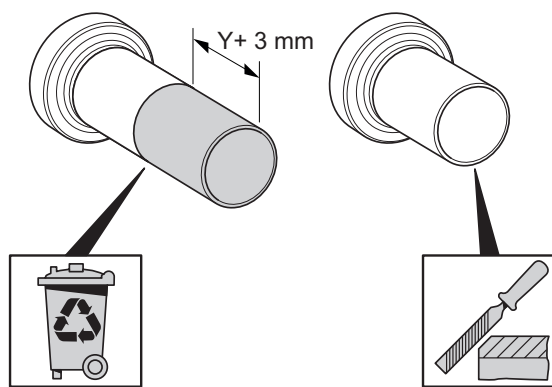

9

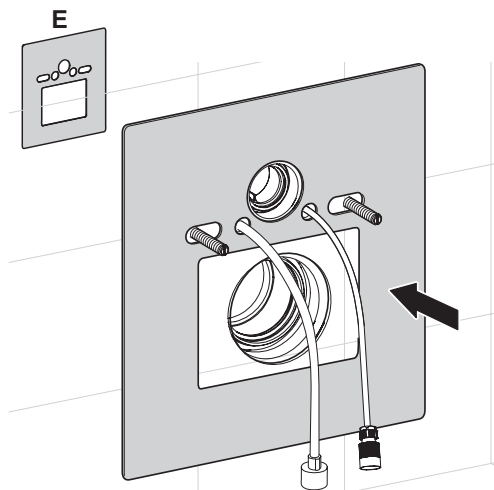

10

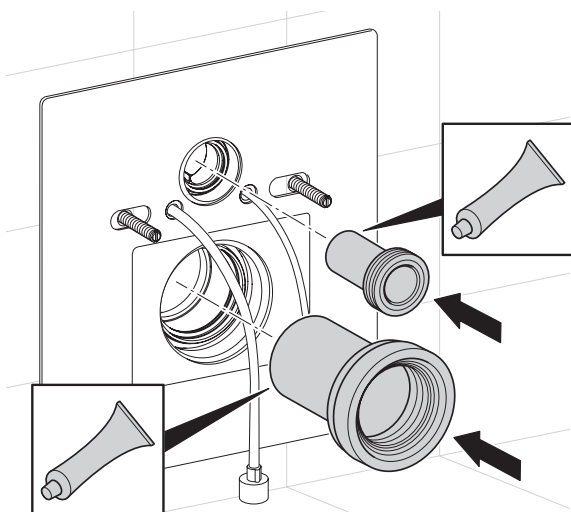

11

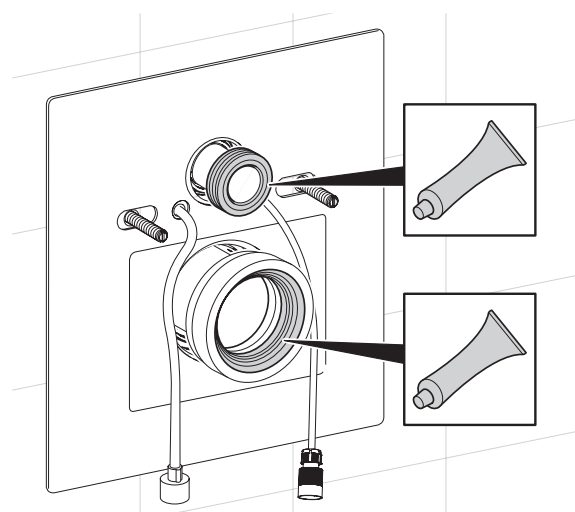

12

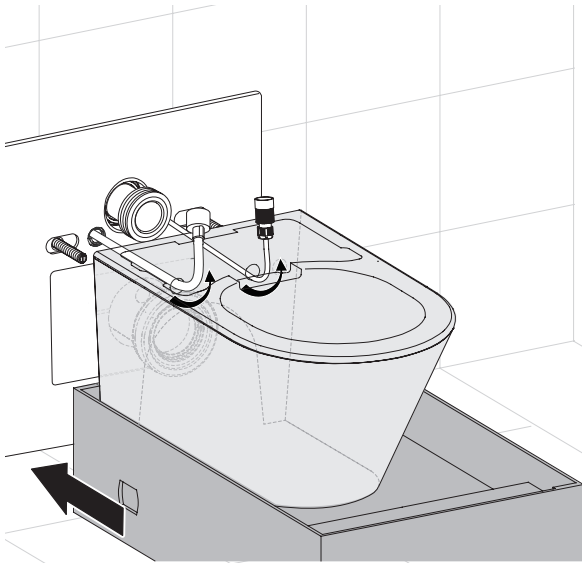

13

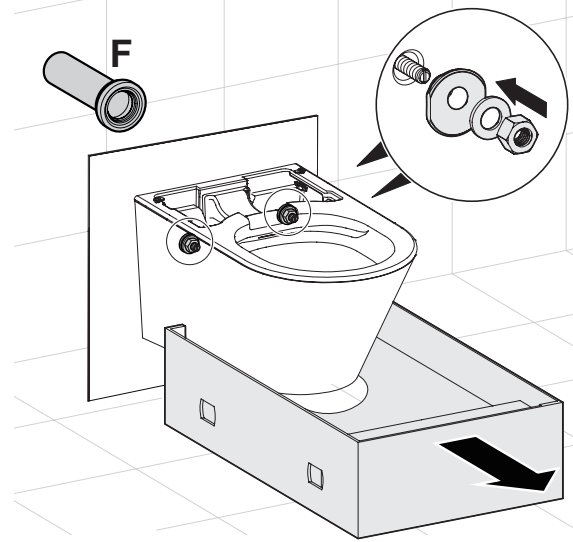
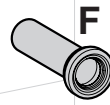

14

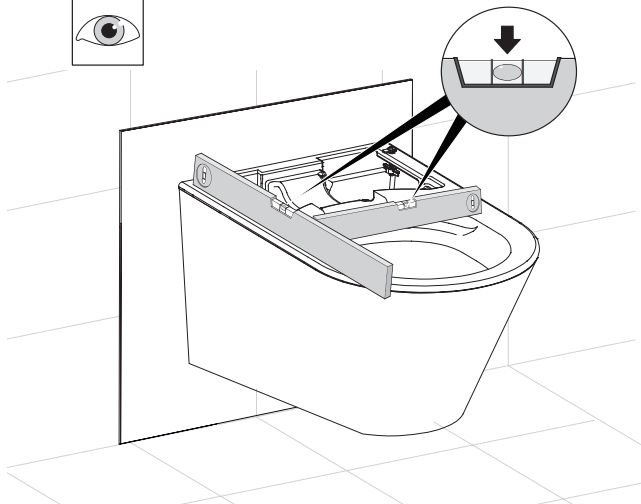

15

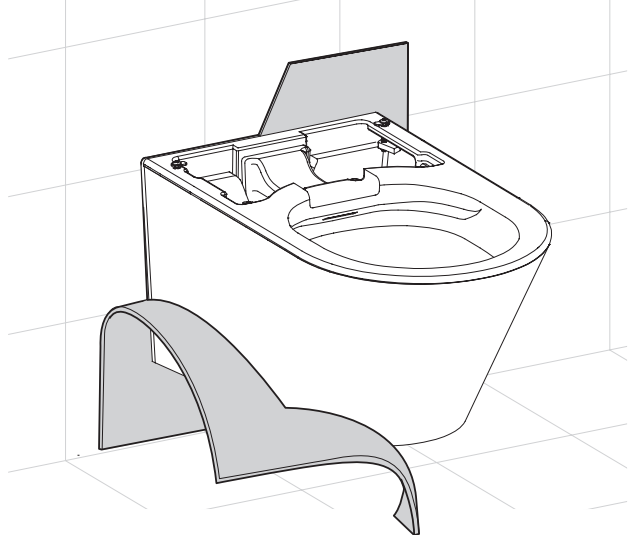

16

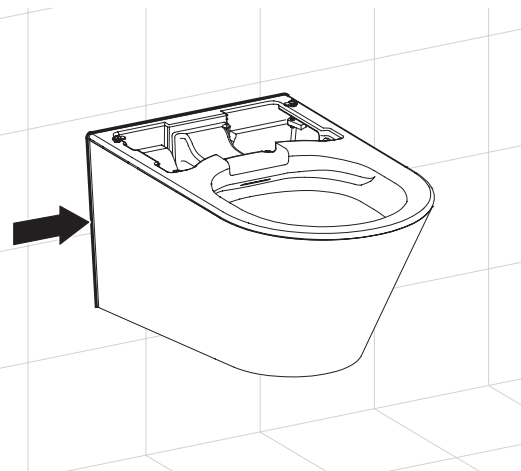

17

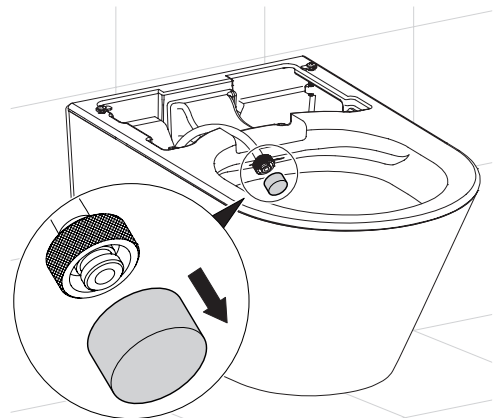

18

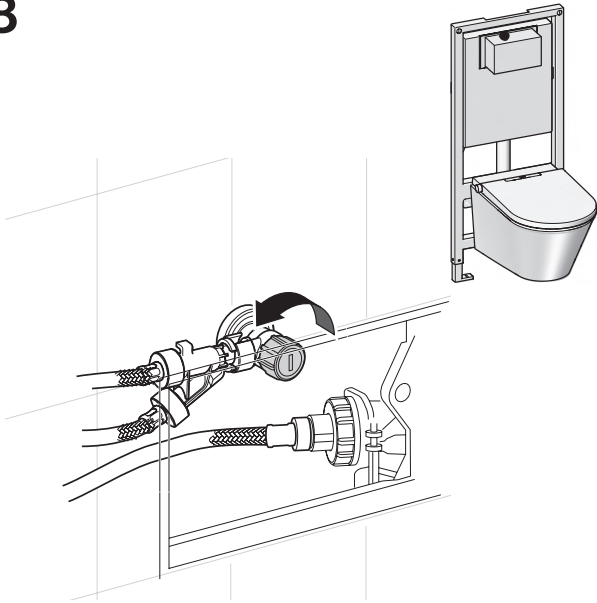

19

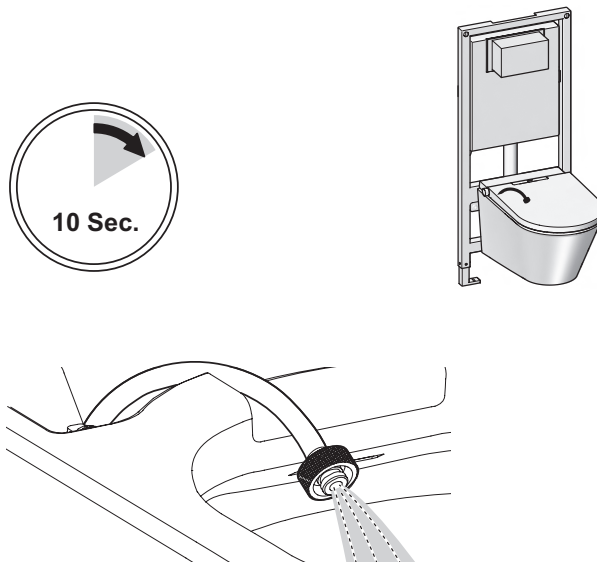

20

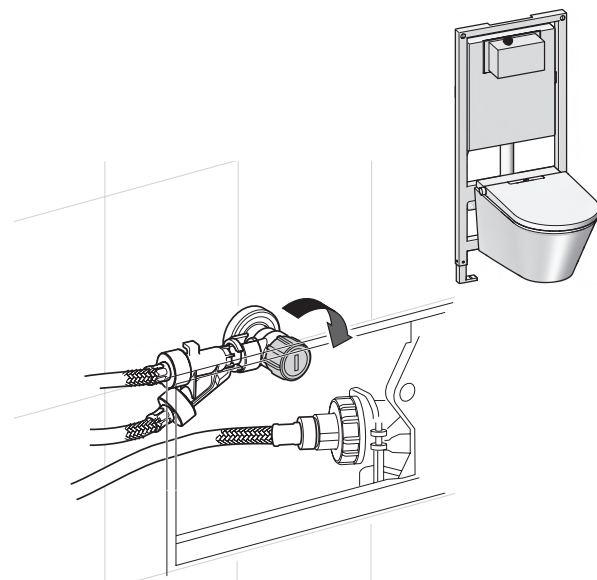

21

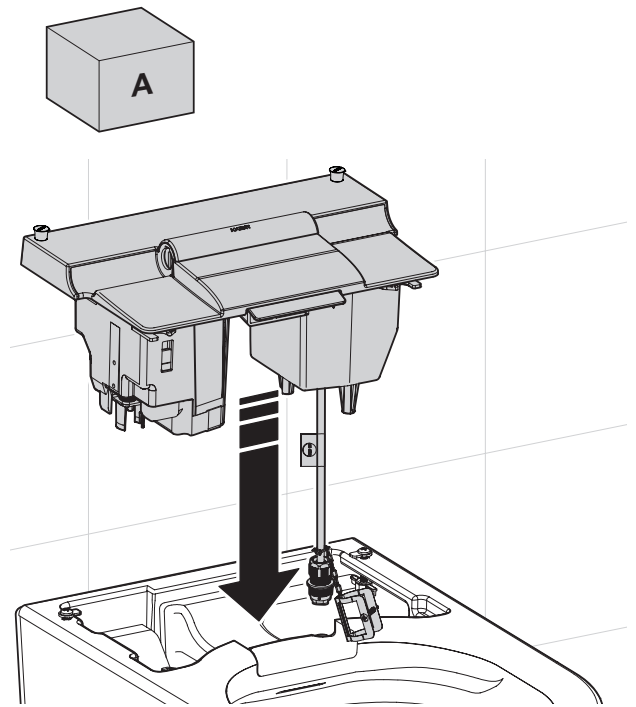

22

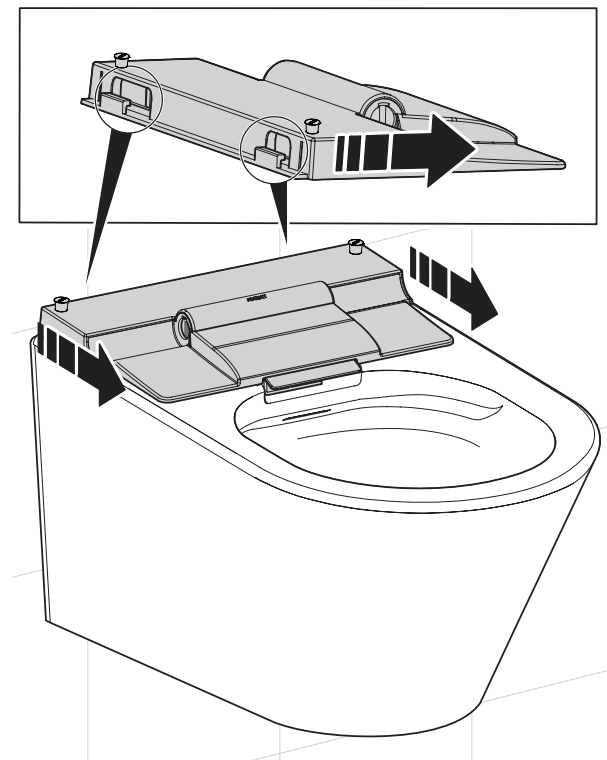

23

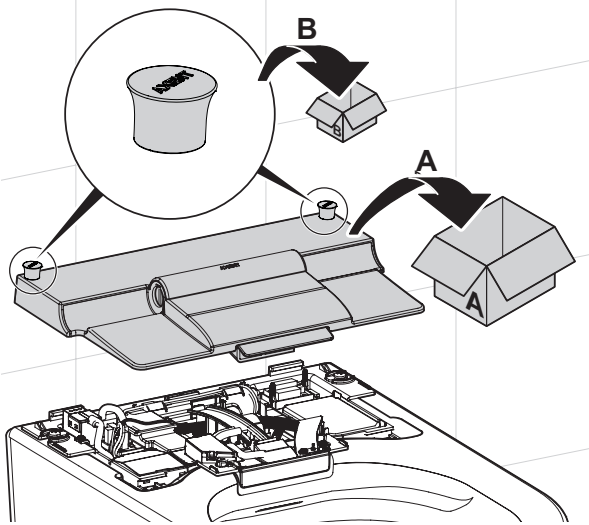

24

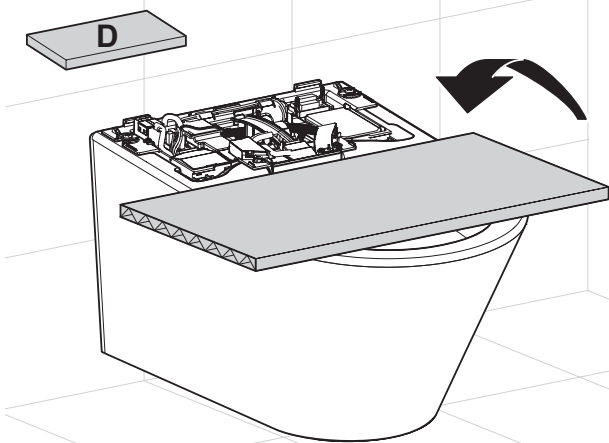

25

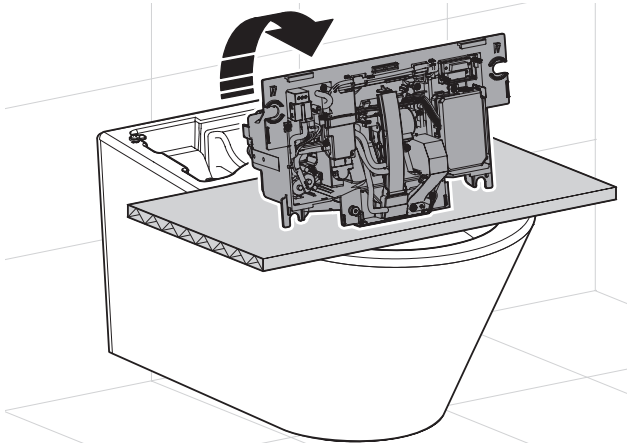

3

A

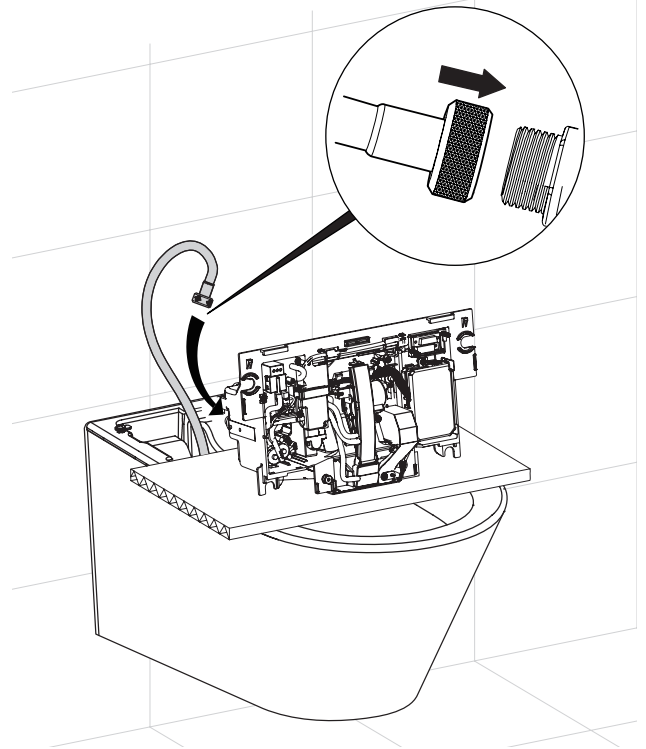

3

B

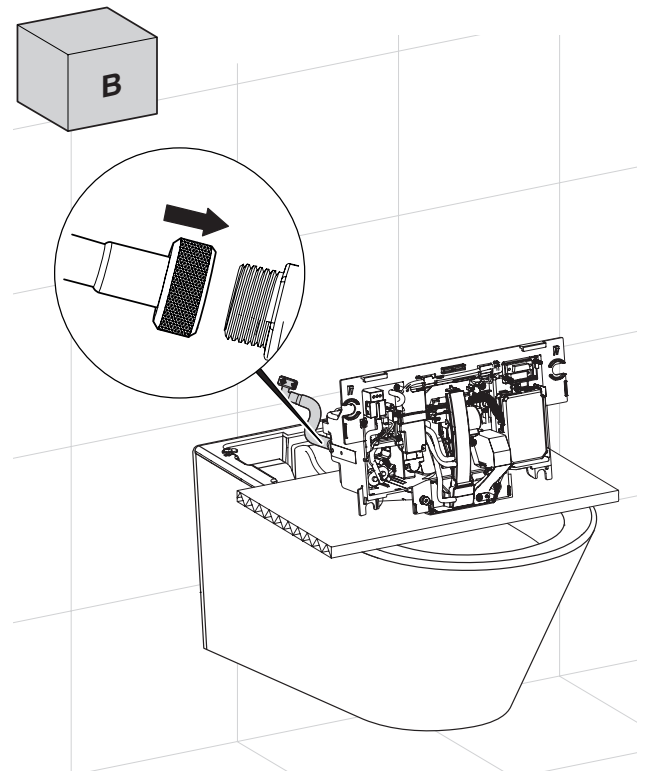

4

1  PH 2

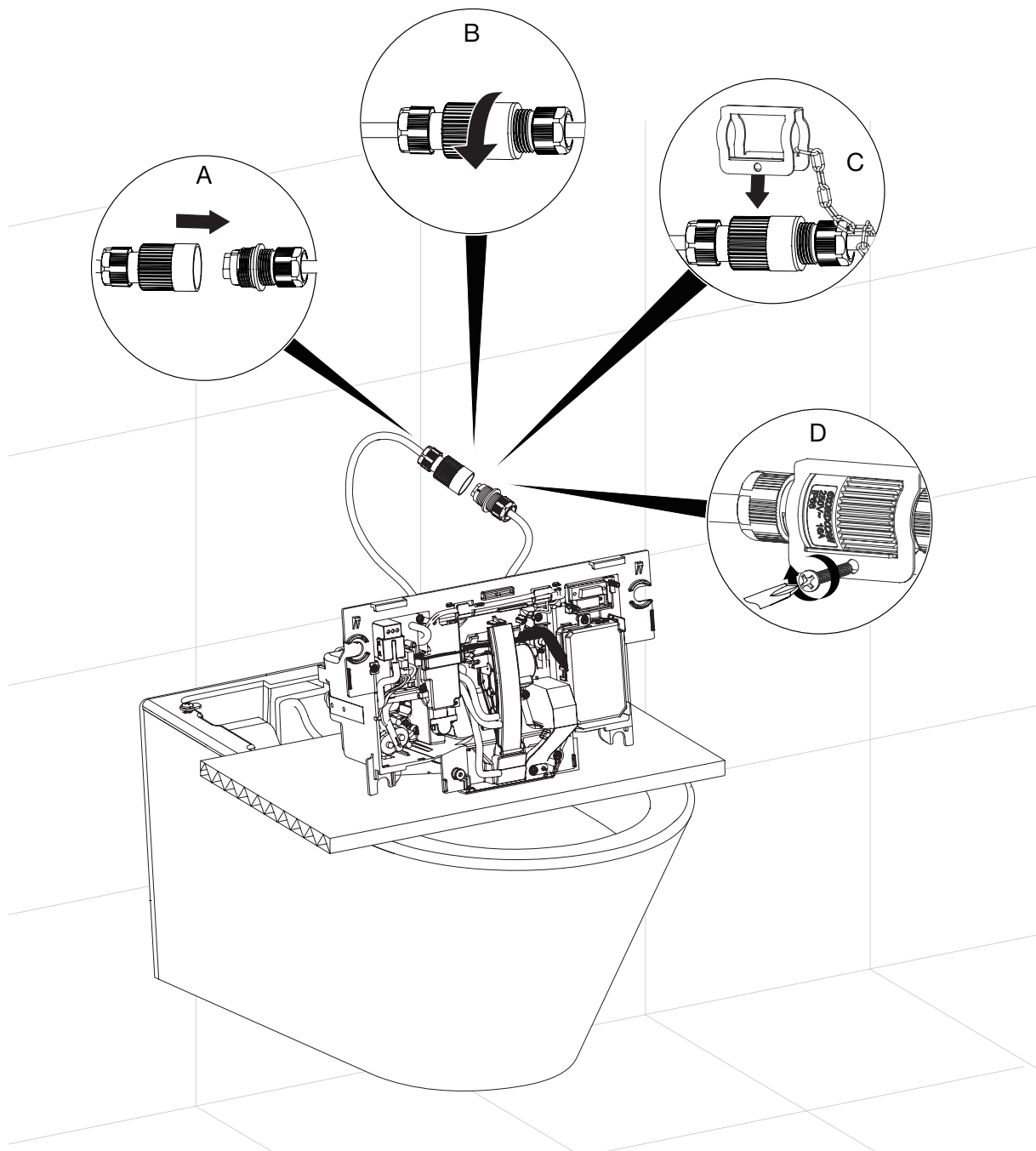

2

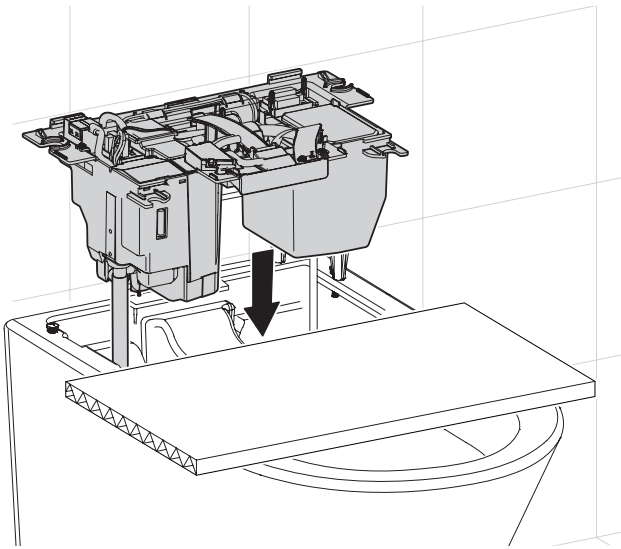

3

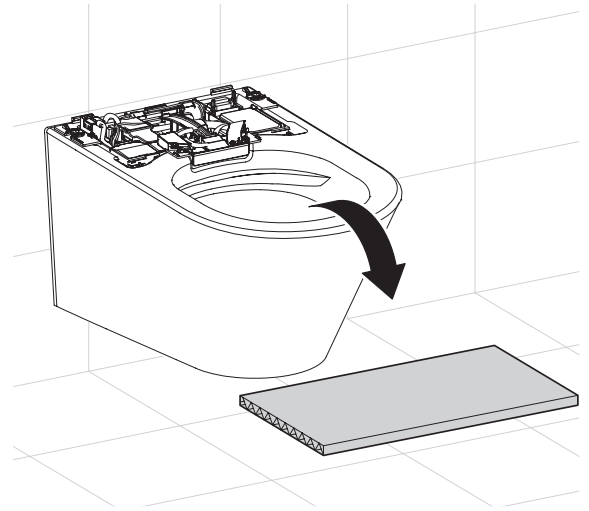

4



PH 2

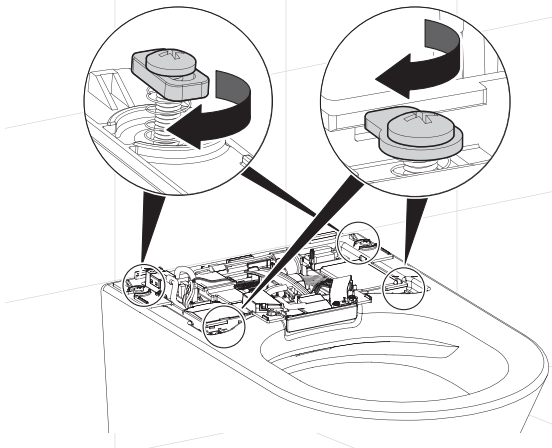

5

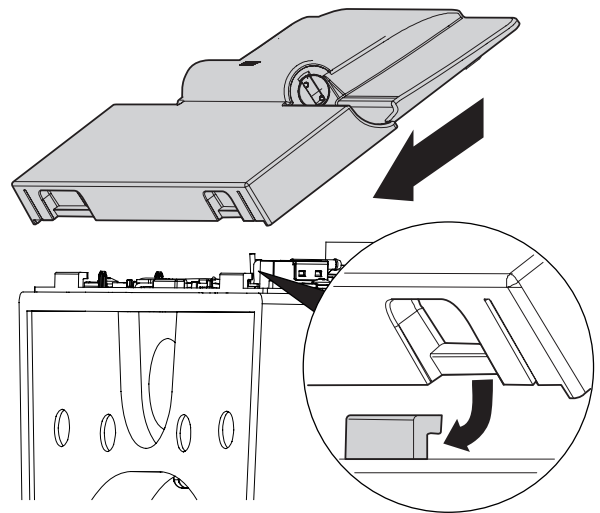

6

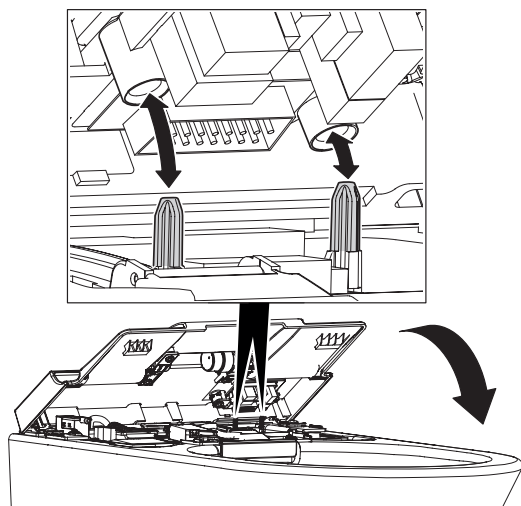

7

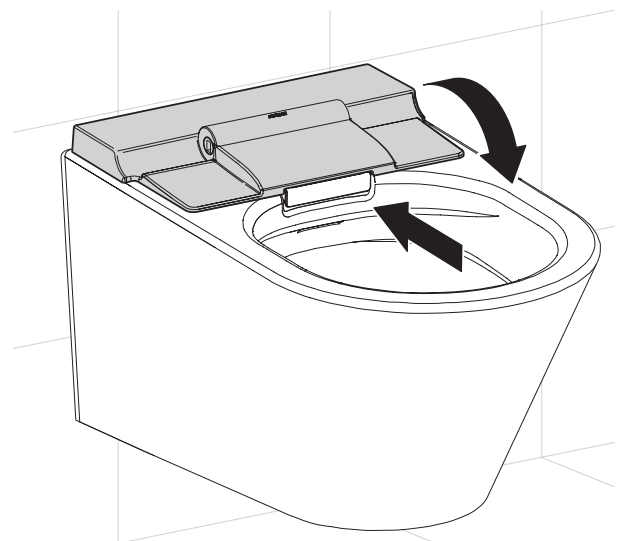

8

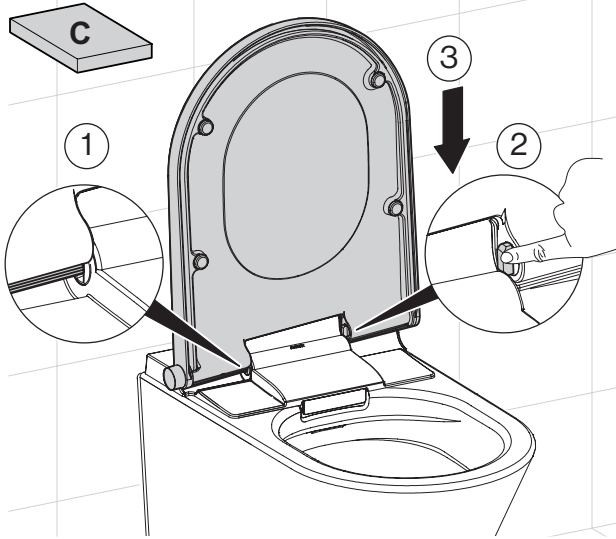

9

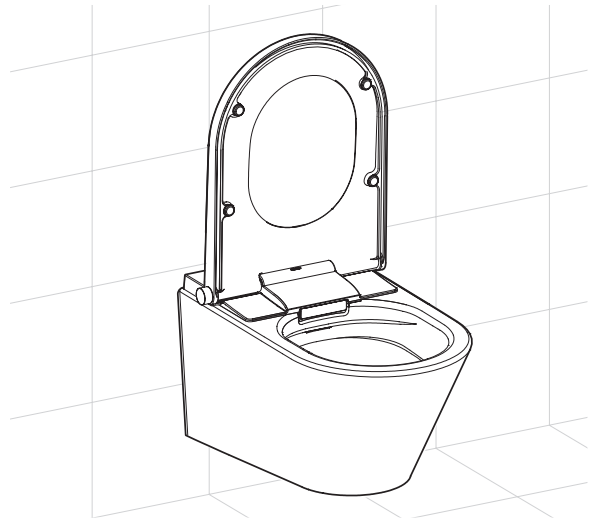

10

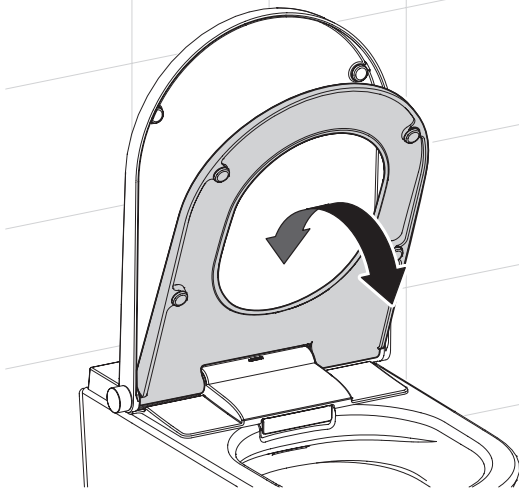

5 A

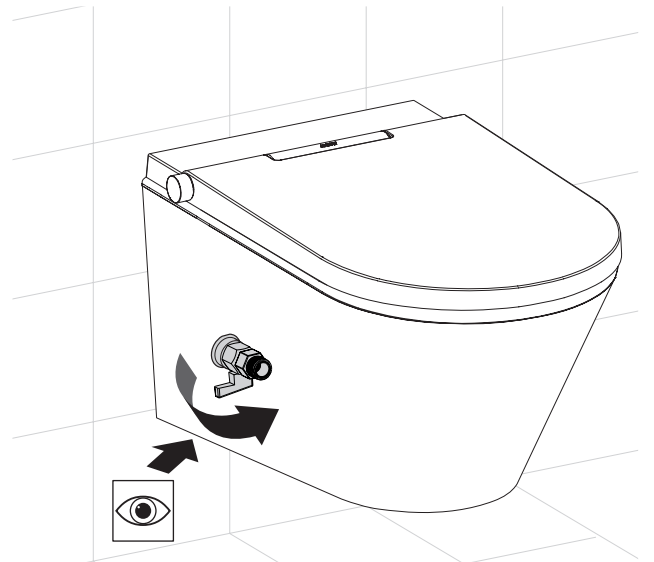

11

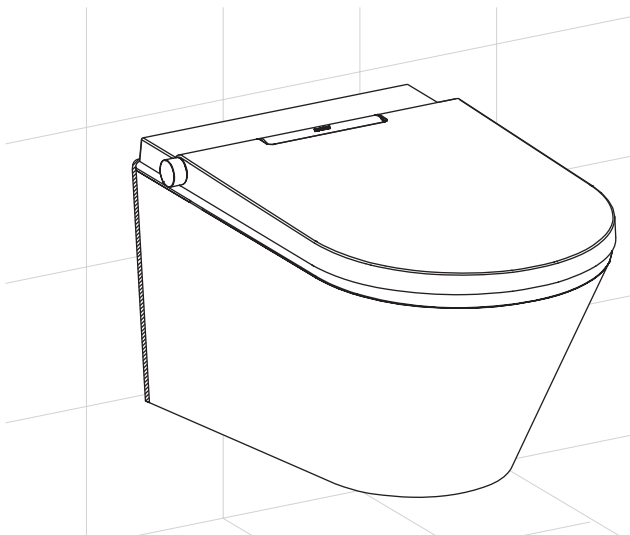

5 B

1

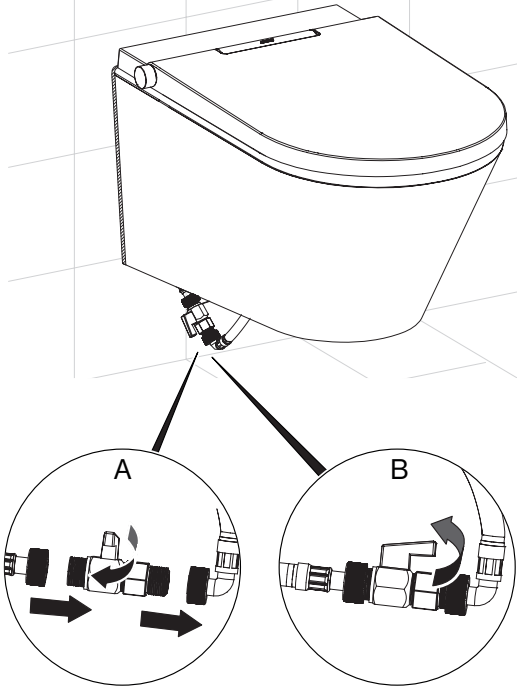
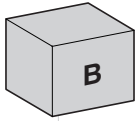

2

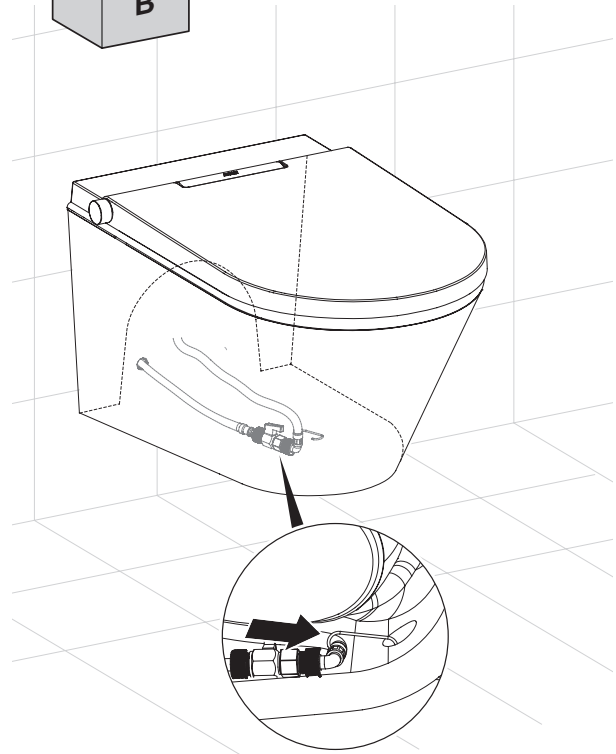
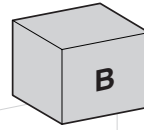

6

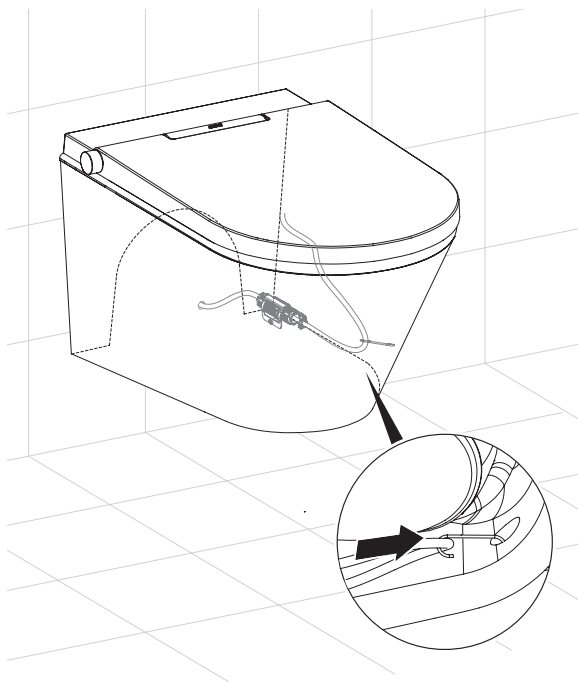
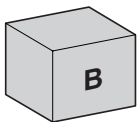

7 A

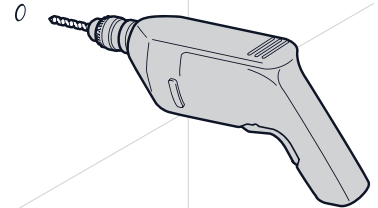
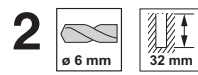
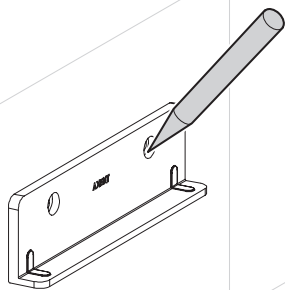
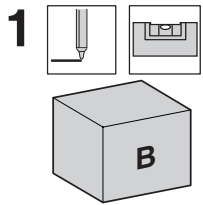

3

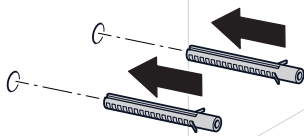

1

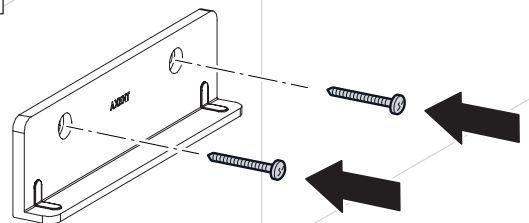

2

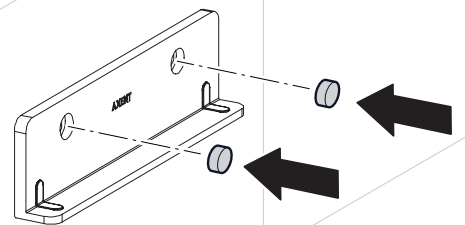

5

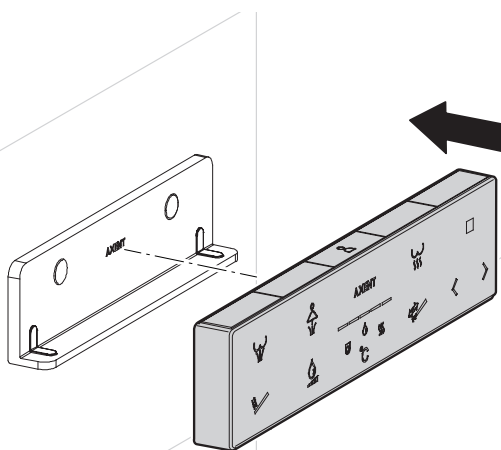

6

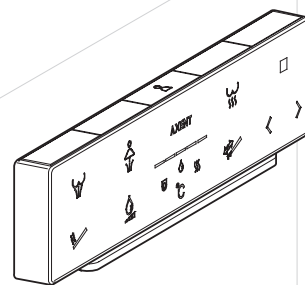

7 B

1

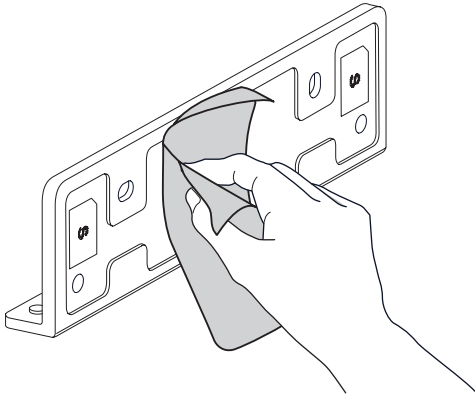

2

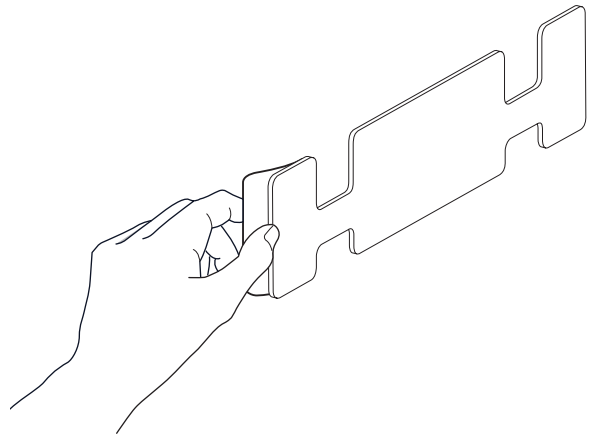

3

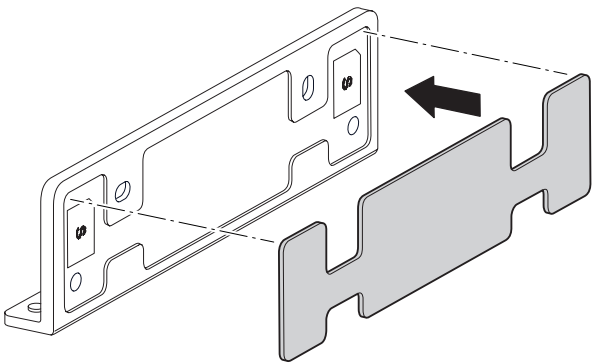

4

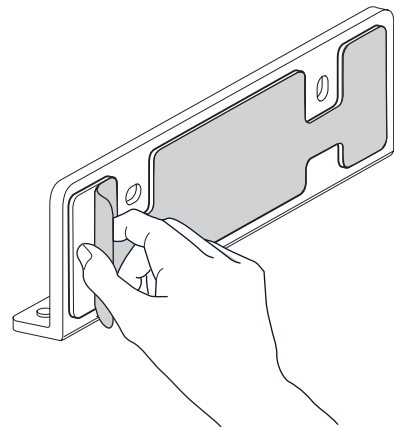

5

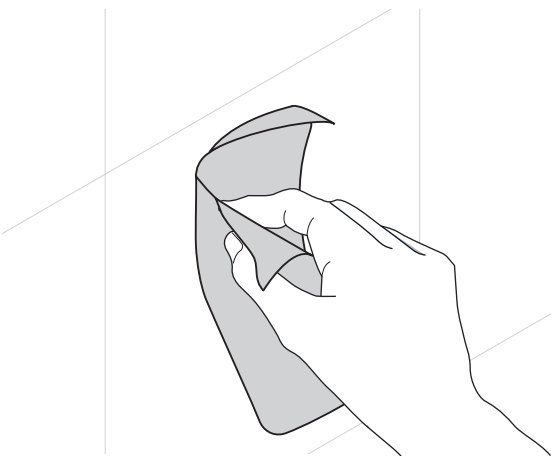

6

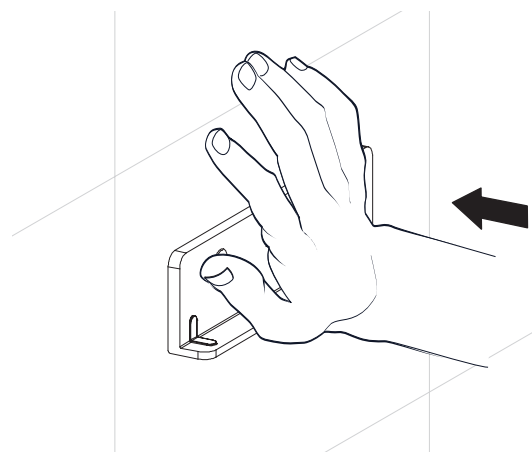

7

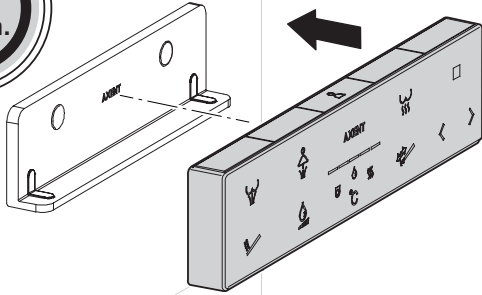

8

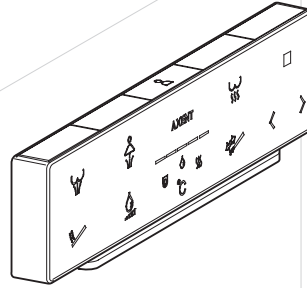

7 **C**

1

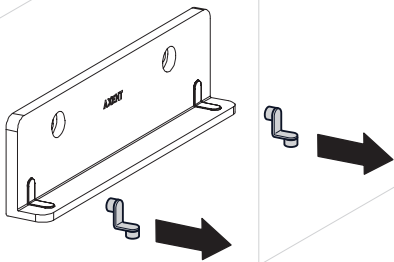

2

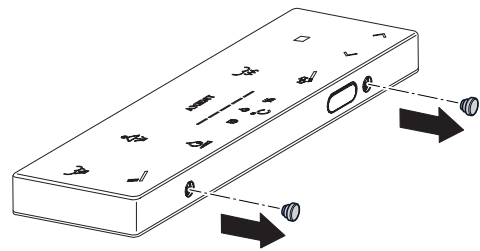

3

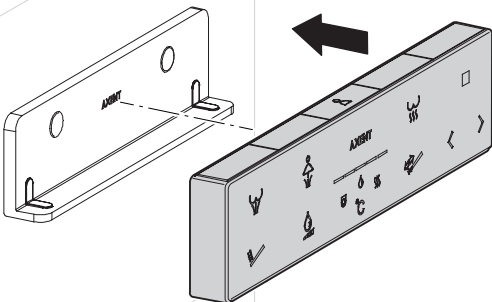

4

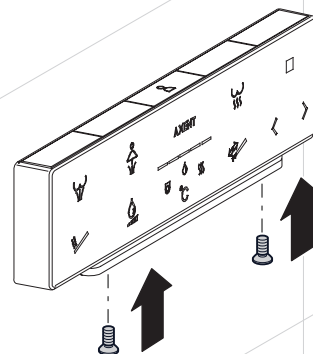



Prüfverfahren nach Montage
Test after installation
Procédure d'essai après le montage
Procedura di collaudo dopo il montaggio
Testprocedure na montage
Proceso de comprobación después del montaje
Processo de verificação após a instalação
Afprøvningsprocedure efter montering
Testing etter montering
Provning efter monteringen
Asennuksen jälkeiset tarkastustoimenpiteet

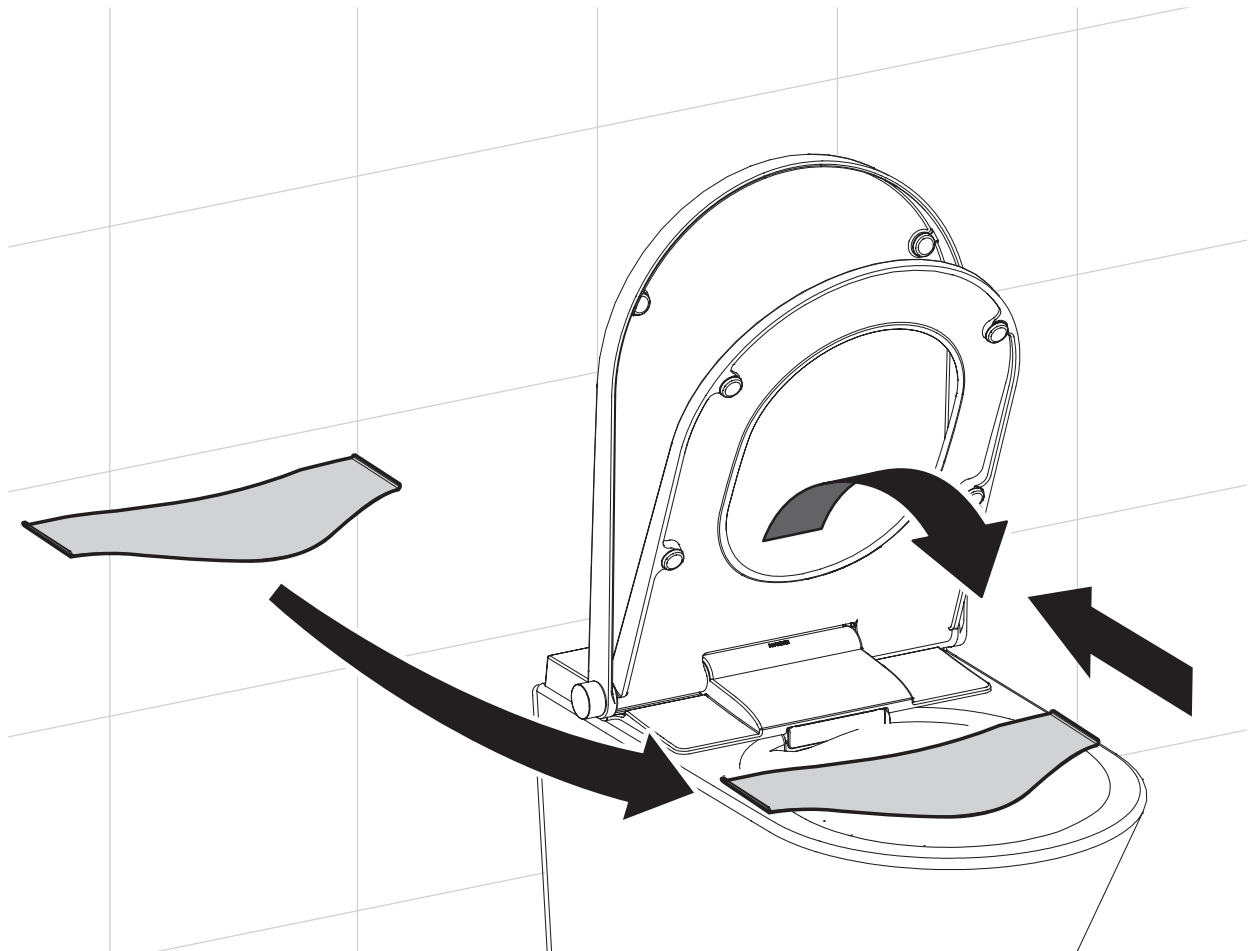

8 **A**

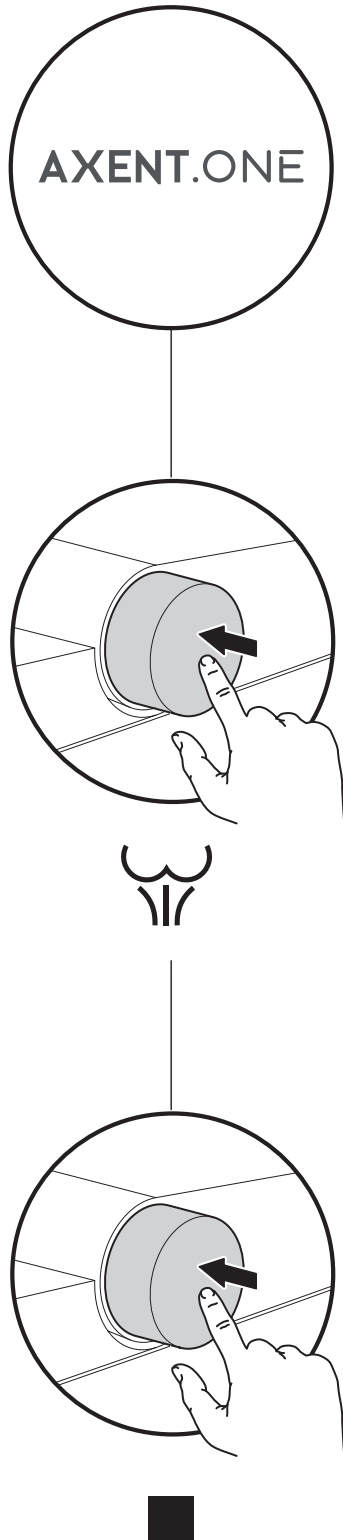

8 **B**

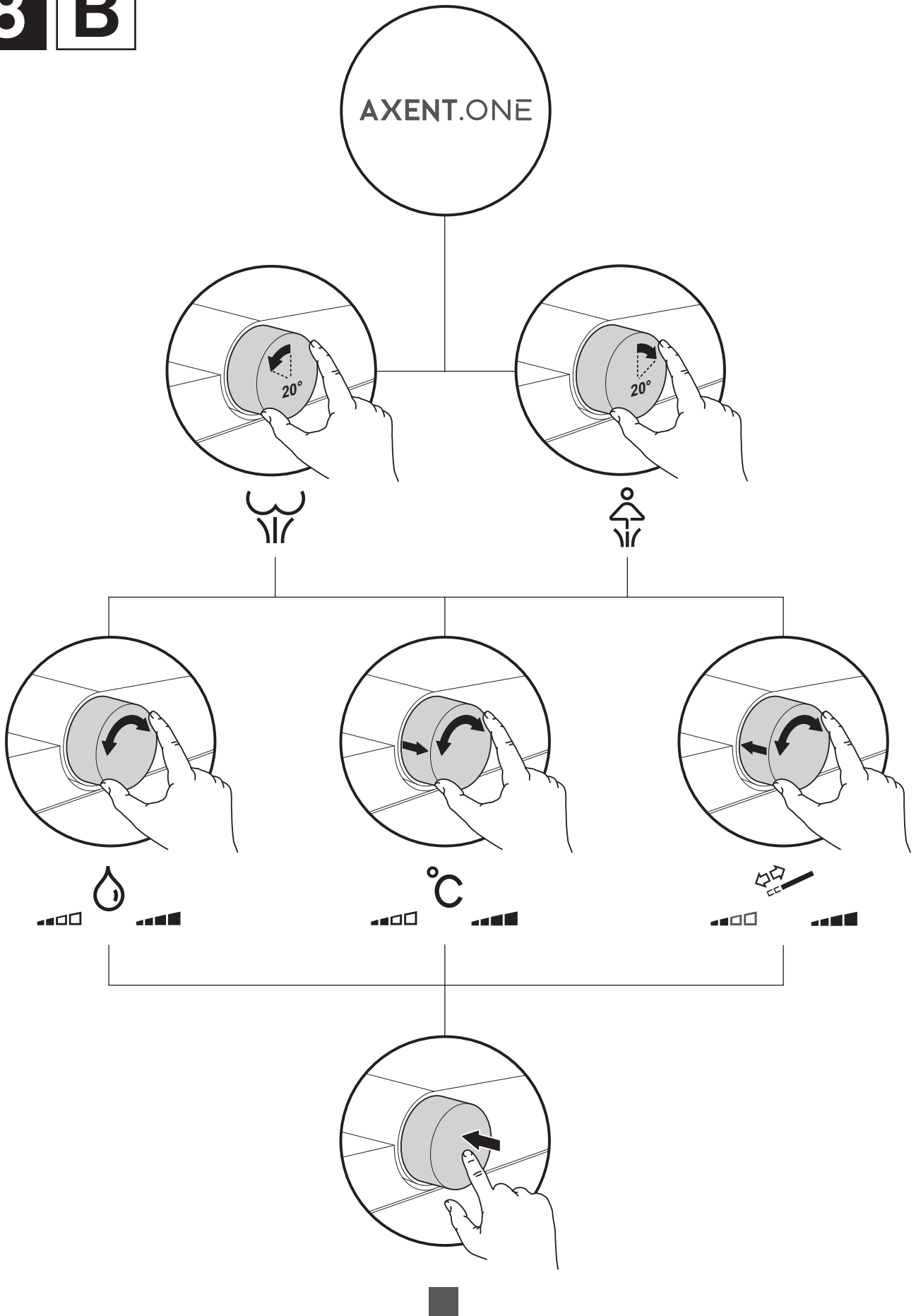

AXENT International AG

info@axentbath.eu

www.axentbath.eu